



info@elmeco.com
www.elmeco.com

ITALY HEADQUARTER

via Circumvallazione Esterna, 12
80025 Casandrino,
Napoli, Italy
Tel +39 081 5055724
Fax +39 081 5055726

AMERICA DISTRIBUTION CENTER

652 Griffith Road Suite E
Charlotte NC
28217, USA
Tel: +1 877 435 6326
Fax +1 704 666 5141

INDIA DISTRIBUTION CENTER

5th Floor, Sangeet Plaza
Marol Maroshi Road
Opp Marol Fire Brigade
Andheri (East) Mumbai
India 400 059



UP TO
5 YEARS WARRANTY
5 years on compressor parts (USA / Canada only)
3 years on electronic parts (USA / Canada only)
2 years on functional parts
1 years on labor

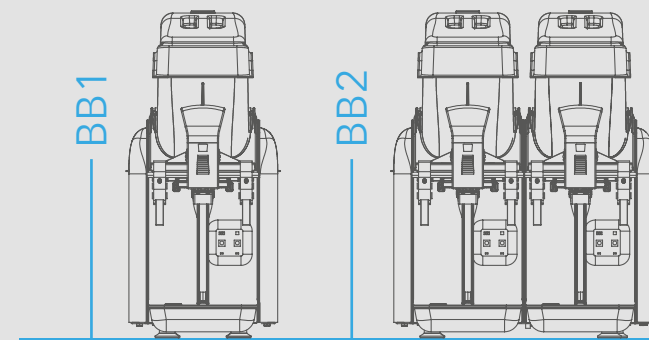

COLOURS AVAILABLE

DIMENSION	WEIGHT		CAPACITY		POWER		VOLTAGE			
	H	W	D	KG.	LB.	LT.		GAL.	W	HP
BB1	552 mm 21.8 inc	250 mm 9.90 in	475 mm 18.7 in	22	48.50	6	1.58	450	0.60	220/240/50 220/60 115/60 100/50-60
BB2	552 mm 21.8 inc	440 mm 17.3 in	475 mm 18.7 in	32	70.50	12	3.17	560	0.75	220/240/50 220/60 115/60 100/50-60

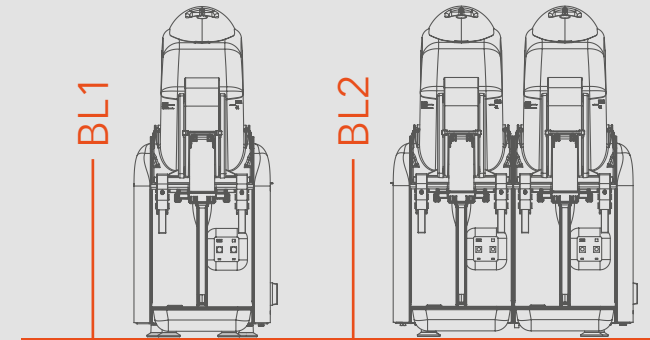

COLOURS AVAILABLE

DIMENSION	WEIGHT		CAPACITY		POWER		VOLTAGE			
	H	W	D	KG.	LB.	LT.		GAL.	W	HP
BL1	606 mm 23.8 inc	250 mm 9.90 in	463 mm 18.23 in	22,2	49	7,5	1.98	450	0.43	220/240/50 220/60 115/60 100/50-60
BL2	606 mm 23.8 inc	440 mm 17.3 in	463 mm 18.23 in	32.5	71.65	15	3.96	560	0.72	220/240/50 220/60 115/60 100/50-60

Frozen Granita and Sorbet Machines

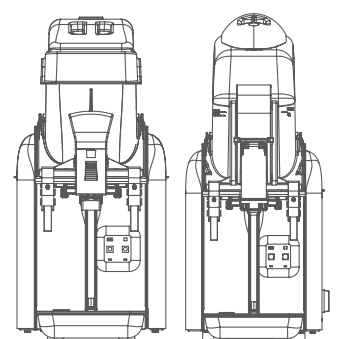

all you can slush



Exclusive Features

Compact & Easy

Total cold system

"Seal-Less" drive shaft system which eliminates mandatory preventive maintenance

Electronic system, density control and auto diagnostics

Removable external condenser air-filter



frozen cocktail



sorbetto



granita



frozen cream



Extremely flexible and space-saving, **Elmeco Big Biz** guarantees big profits, with the added bonus of low investment and maintenance costs. Big Biz machine is easy to use and clean, produces small quantities of granita, making it **easy to adapt the product** to suit your clients' ever-changing tastes. Perfect for Italian-style granita, iced coffee and tea, soft drinks, desserts, sorbets ice-cold cocktails, lemonade and much more. **Discover new recipes, invent new flavours.**



Exclusive Features

Quick serve dispensing system

Total cold system

"Seal-Less" drive shaft system which eliminates mandatory preventive maintenance

Electronic system, density control and auto diagnostic

Removable external condenser air-filter



milkshake



sorbetto



granita



frozen cream



Elmeco BLarge is a young but highly proficient machine, resulting from Elmeco's many years of experience in the field. Highly reliable and compact, it still maintains all the necessary technical features of Elmeco machines, and also comes with quick dispensing system helps with many erogations to do. Perfect for granita, frozen desserts, frozen coffee, tea and yogurt, cocktails, sangria, lemonade and much more.

