



info@elmeco.com
www.elmeco.com

ITALY HEADQUARTER

via Circumvallazione Esterna, 12
80025 Casandrino,
Napoli, Italy
Tel +39 081 5055724
Fax +39 081 5055726

AMERICA DISTRIBUTION CENTER

652 Griffith Road Suite E
Charlotte NC
28217, USA
Tel: +1 877 435 6326
Fax +1 704 666 5141

INDIA DISTRIBUTION CENTER

5th Floor, Sangeet Plaza
Marol Maroshi Road
Opp Marol Fire Brigade
Andheri (East) Mumbai
India 400 059

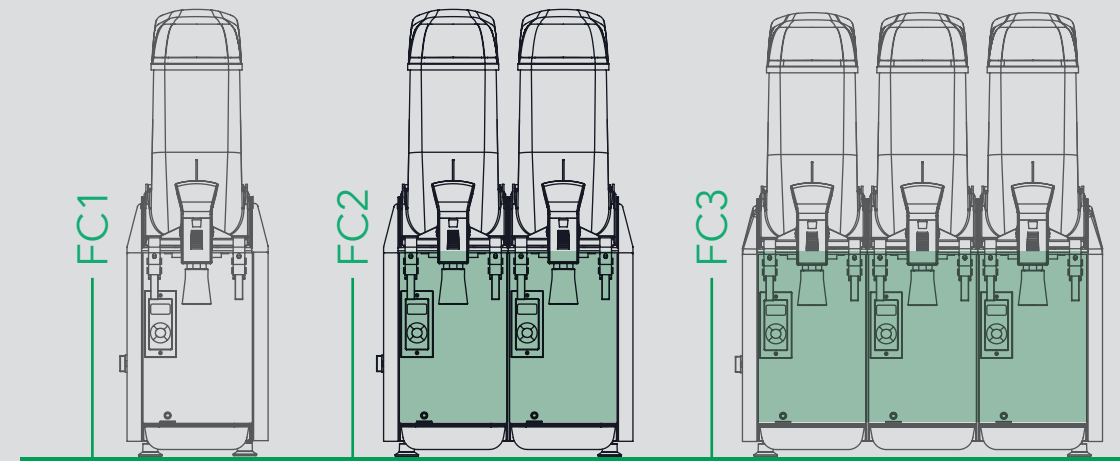

○ ● COLOURS AVAILABLE ■ FRONT LED BACKLIT LIGHT PANEL AVAILABLE

DIMENSION	WEIGHT		CAPACITY		POWER		VOLTAGE			
	H	W	D	KG.	LB.	LT.		GAL.	W	HP
FC1	771 mm 30.35 inc	240 mm 9.45 in	566 mm 22.28 in	31	68.30	12	3.17	500	0.67	220/240/50 220/60 115/60
FC2	771 mm 30.35 inc	430 mm 16.93 in	548 mm 21.57 in	52	114.60	24	6.34	930	1.24	220/240/50 220/60 115/60
FC3	771 mm 30.35 inc	620 mm 24.4 in	548 mm 21.57 in	64	141.10	36	9.51	1150	1.54	220/240/50 220/60 115/60



5 years on compressor parts (USA / Canada only)
3 years on electronic parts (USA / Canada only)
2 years on functional parts
1 years on labor

Keep your First Class tanks full at all times

AUTO-FILL SYSTEM BENEFITS

Bag-n-box (BIB) auto fill system product at rate of 2-3 oz per sec. (varies for different types of concentrate);

Power cord included, must be plugged in individually from the machine (110V/60Hz);

Equipped with automatic cleaning and sanitizing valves;

Contains pumps, tubes and solenoids in one, easy to handle box;

Equipped with automatic alarm when syrup BIB empty or insufficient water pressure provided;

Equipped with shurflo brix pumps at 3:1, 4:1 or 5:1.

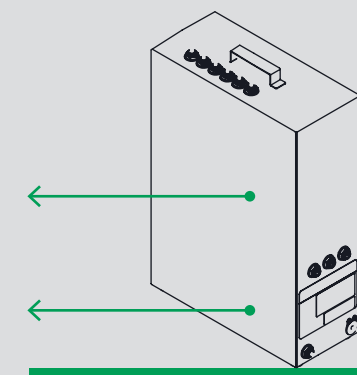

Frozen Drink & Cocktail Machines

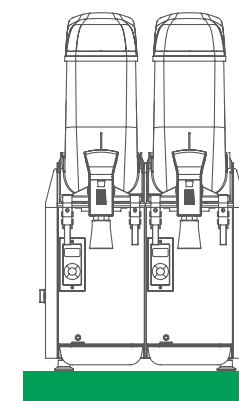

Exclusive Features

Double augers for Better mix
Total cold system
"Seal-Less" drive shaft system which eliminates mandatory preventive maintenance
Electronic system, density control and auto diagnostic
Equipped with automatic cleaning and sanitizing valves



milkshake



cold drink

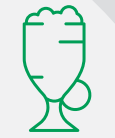

smoothie



frozen cocktail



granita



PROPANE GAS R290
BRUSHLESS FUN MOTOR
REMOVABLE AIR FILTER
SELF CLEANING CONDENSER

First class

Particularly suitable for locations with a large number of users, **Elmeo First Class** is perfect for granita, frozen coffee and tea, semi-frozen and frozen desserts, cocktails, sorbets, sangria, lemonade and much, much more. Thanks to the patented **"total cold" system**, the product is kept at a constant temperature, right down to the very last drop, guaranteeing optimal product quality and minimal wastage. **Completely drive shaft seal free** make the machine is to disassembly and clean. An efficient, electronic board makes it simple and intuitive to use.

Exclusive customization with Led Backlit light panel

Elmeo First Class is available in two different color and it is possible to customize with your logo, graphics or advertising messages. The addition of the **LED backlight panel** allows for complete customisation and a fresher, more appealing look.



First class

Refill system. Maximize your output production

Elmeo Refill is a handy bag-in-box auto-fill system, easy to set up on the existing machines (FC2 and FC3). This additional equipment maximizes output production by keeping machine **bowls full at all times** and reinforces merchandizing effect. Eliminates potential human errors in process of premixing water and syrup.

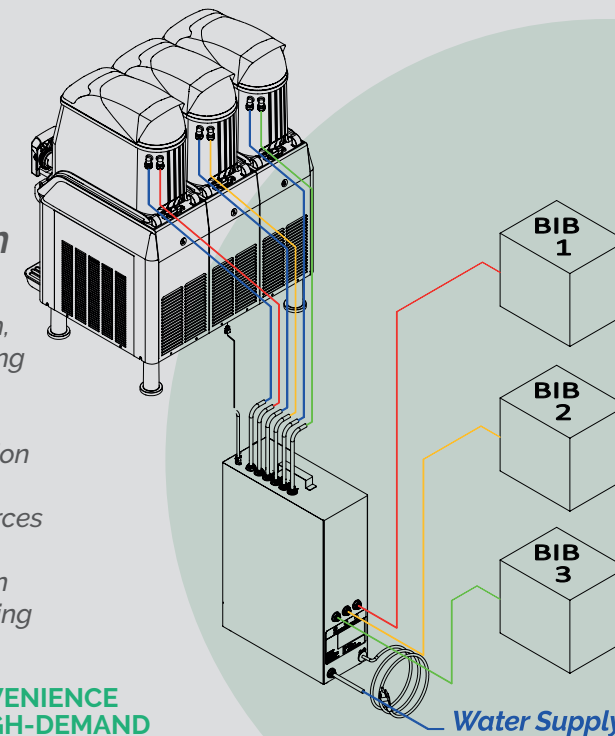

IDEAL FOR CONVENIENCE STORES AND HIGH-DEMAND BEVERAGE SERVICE